

RESERVE COPY
PATENT SPECIFICATION



Convention Date (France): March 26, 1931.

369,080

Application Date (in United Kingdom): May 28, 1931. No. 15,642/31.

Complete Accepted: March 17, 1932.

COMPLETE SPECIFICATION.

Improvements in Stands for Flasks.

I, RENÉ LALIQUE, of 40, Cours Albert
ler, Paris, France, a French citizen, do
hereby declare the nature of this inven-
tion and in what manner the same is to
be performed, to be particularly described
and ascertained in and by the following
statement:—

Liquor flask stands in which the
various flasks are held by means of a
rocking device allowing the flasks to be
released for use are known.

This invention relates to a stand for
bottles or flasks comprising a base mem-
ber and a keeper, wherein the base is
provided with movable locking members
adapted to engage recesses in the bottoms
of the bottles, whereby a more sober and
pleasing appearance is given to the article
as a whole.

An embodiment of a liquor flask stand
constructed according to the invention is
shown by way of example in the appended
drawings.

Figure 1 is a general perspective view;

Figure 2 is a horizontal cross section
corresponding to Fig. 1;

Figure 3 is a horizontal cross section
relating to a detail modification of the
said stand.

The stand comprises primarily a base 1
on which the various flasks as 10 are sup-
ported, which are separated by the up-
rights as 3 and 4 of a frame comprising
in addition an upper cross member 5 and
a projection 6 to serve as a handle.

The flasks 10 can be shifted into a
definite position on the base 1 until they
bear against centering projections or lugs
2. Also the flasks which may have a
circular or any other suitable section, are
moulded at their bottoms with a recess 7.

When the flasks are suitably positioned
on the base, the recess 7 in each of them
receives the bolt 8 of a common lock 9
in such manner that when the lock is
closed the flasks retained by the bolts will
be locked in.

To release the flasks for use, it is only

necessary to open the lock, which allows
the flasks to be slid on the base until the
stoppers thereon are disengaged from the
upper cross member 5. The uprights 3
and 4 may have any suitable shape, par-
ticularly that of a square (Fig. 2) or an I
(Fig. 3, 4a—3b). Similarly, the lock
bolts may have any suitable shape, e.g.
square or round, as shown at 8 in Fig. 2
and at 8¹ in Fig. 3 respectively.

It is to be understood that any other
shape or arrangement both of the frame
and the base may be resorted to, par-
ticularly as to the contour of the uprights
and the stops in the base adapted to posi-
tion the flask bottoms, the stops for the
flasks being provided by a projecting
frame or by abutments, etc.

The base, frame and uprights may be
made of any suitable material and pro-
vided with any suitable decoration and
fixtures adapted conveniently to complete
the equipment of the liquor flask stand.

Having now particularly described and
ascertained the nature of my said inven-
tion and in what manner the same is to
be performed, I declare that what I claim
is:—

1. A stand for bottles or flasks compris-
ing a base member and a keeper, wherein
the base is provided with movable lock-
ing members adapted to engage recesses
in the bottoms of the bottles.

2. An arrangement as claimed in claim
1 in which the locking members are con-
trolled by a key-operated device provided
in the base of the stand.

3. A stand as claimed in claim 1 or 2 in
which the keeper member is provided
with a handle portion.

4. A stand for bottles or flasks substan-
tially as described and illustrated.

Dated this 28th day of May, 1931.

DICKER, POLLAK & MERCER,
Chartered Patent Agents,
20 to 23, Holborn, London, E.C. 1,
Agents for the Applicant.

[This Drawing is a reproduction of the Original on a reduced scale.]

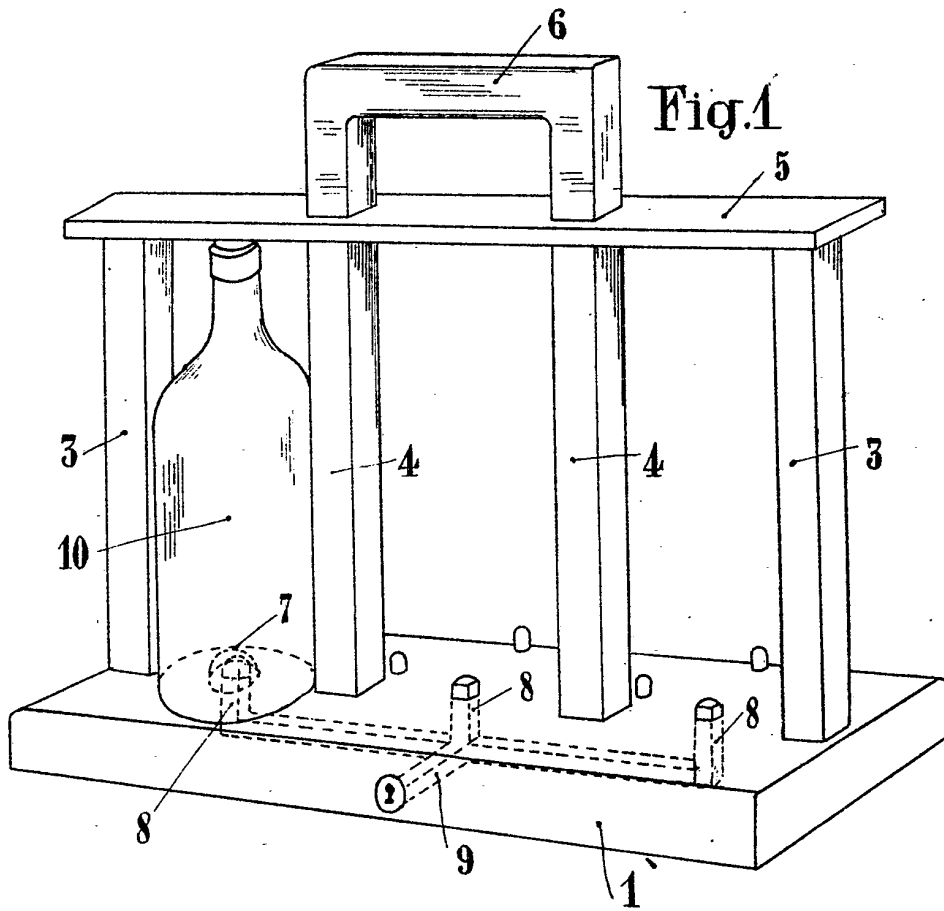

Fig. 2

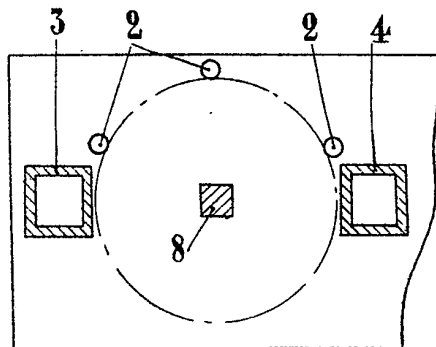

Fig. 3

